

Overall Design of the Main Bridge of Hutuo River Extra Large Bridge

Zineng Chen ^{1,*} and Xing Wu ²

¹ Tongji Architectural Design (Group) Co., Ltd., Shanghai 200092, China;

² CCCC First Highway Consultants Co. Ltd Xi'an 710075, Shaanxi Province, China.

* Correspondence: 375859229@qq.com

Abstract: The main bridge of the Hutuo River Bridge, a single-tower, single-pylon cable-stayed bridge, is inspired by "landscape painting", featuring a unique "scroll-shaped" tower with a spatially twisted cable arrangement. The bridge has a span arrangement of (40 + 150 + 150 + 40) meters and utilizes a fully floating system. The structural support system incorporates vertical seismic isolation bearings, longitudinal and transverse dampers, and transverse wind-resistant bearings. The tower's cross-section transitions from oval at the base to circular at the top, with decorative scroll edges rotating counterclockwise at approximately 90° from the base to the top. The tower above the deck is steel, while the part below the deck is concrete, with a steel-concrete transition section near the deck level. The main girder uses a double-box steel structure with transverse beams. The stay cables are made of 1860 MPa-grade steel strands, with an anchorage spacing of 9.0 m along the cable-stayed beam. Unlike the traditional fan-shaped cable arrangement, this bridge adopts a reverse layout, with the outermost cable having the lowest anchorage point on the tower. The foundations for the bridge towers, auxiliary piers, and edge piers are all constructed using bored piles.

Keywords: Cable-stayed bridge; Single-tower and single-pylon; Fully floating system; Steel tower cross-section; Steel anchor beam and steel anchor box; Steel strand cables

Citation: Chen, Z.; Wu, X. Overall Design of the Main Bridge of Hutuo River Extra Large Bridge. *Prestress Technology* 2024, 3, 71-83. <https://doi.org/10.59238/j.pt.2024.03.007>

Received: 23/04/2024

Accepted: 08/09/2024

Published: 30/09/2024

Publisher's Note: Prestress technology stays neutral with regard to jurisdictional claims in published maps and institutional affiliations.



Copyright: © 2024 by the authors. Submitted for possible open access publication under the terms and conditions of the Creative Commons Attribution (CC BY) license (<https://creativecommons.org/licenses/by/4.0/>).

1 Introduction

The Hutuo River Bridge is a distinctive urban landscape bridge, inspired by the concept of "landscape painting" and featuring a "scroll" shaped tower design. The elegant design of this bridge makes it a landmark structure within the city (Figure 1). Unlike a typical single-tower cable-stayed bridge, this structure is a single-tower and single-pylon bridge with a visually pleasing main tower and cables arranged in a spatial twist. The bridge deck is wide, accommodating ten lanes of traffic in both directions, along with dedicated pedestrian walkways and non-motorized vehicle lanes. While sharing some stress characteristics and design principles with traditional cable-stayed bridges, this bridge exhibits unique features as well [1].

This report presents a comprehensive overview of the bridge's overall design, encompassing various aspects such as technical standards, construction conditions, the structural support system, bridge tower design, main girder design, cable design, substructure, and auxiliary structures.

2 Project Overview and Overall Layout

2.1 Project Overview

This project is a node control project that crosses the Hutuo River on Fuxing Street. The main technical standards are as follows:

- (1) Road Classification: Urban expressway
- (2) Design Speed: 100 km/h
- (3) Vehicle Load Level: Urban Class A
- (4) Basic Cross Section: Dual-direction, 10 lanes + pedestrian and non-motorized vehicle lanes on both sides; standard width of 67.5 meters

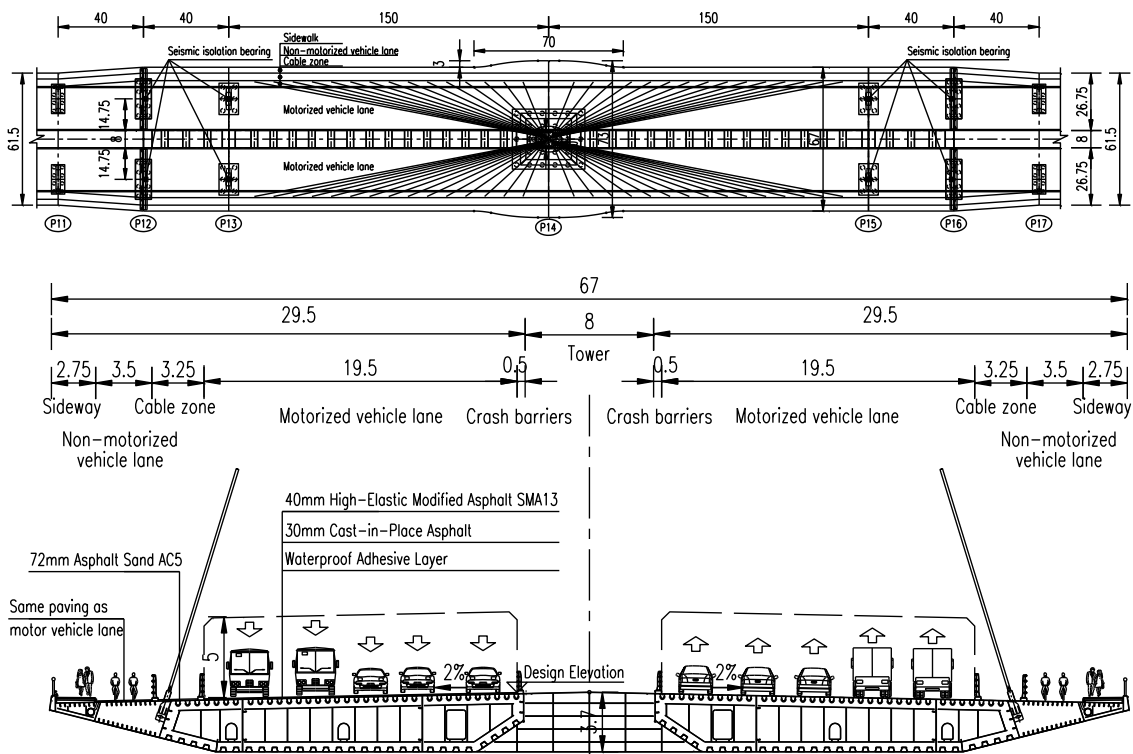

Figure 3 Standard section (Unit: m)

3 Structural Support System

3.1 Structural System

Considering factors such as structural load and aesthetics, the bridge adopts a fully floating system. To meet earthquake resistance requirements while minimizing foundation size, seismic isolation bearings and longitudinal and transverse dampers are used. This fully floating system offers superior technical and economic efficiency compared to a fixed system. To enhance the bridge's wind resistance, transverse wind-resistant bearings are installed at the bridge tower [2]. The bridge's support system is shown in Figure 4.

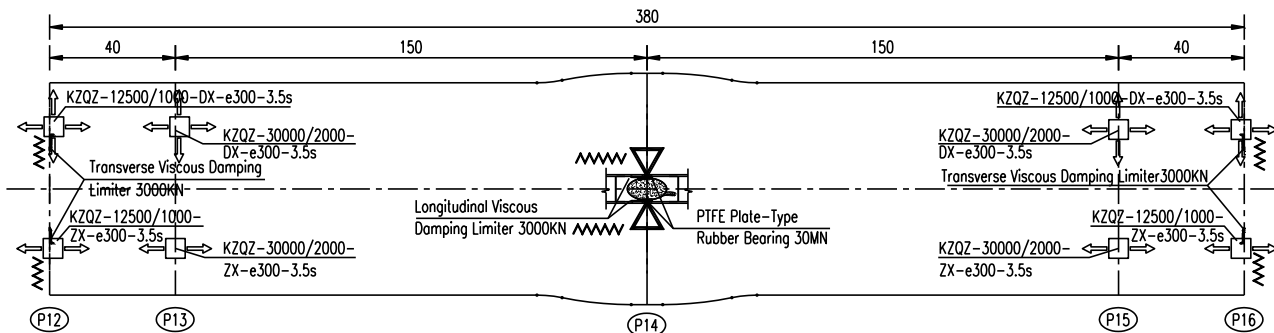

Figure 4 Layout plan of supporting system (Unit: m)

3.2 Seismic Isolation Bearings

Drawing on established practices for single-tower cable-stayed bridge seismic isolation systems [3], the bridge's transition piers and auxiliary piers adopt hyperbolic spherical seismic isolation bearings. These bearings are designed to accommodate a longitudinal and transverse seismic displacement of ± 300 mm. The specific parameters are shown in the Table 1:

Table 1 Parameter table of seismic isolation bearings

Items	Transitional piers		Auxiliary piers	
	KZQZ	KZQZ	KZQZ	KZQZ
Bearing specification model	-12500/1000	-12500/1000	-30000/2000	-30000/2000
	-DX-e300	-ZX-e300	-DX-e300	-ZX-e300
	-3.5 s	-3.5 s	-3.5 s	-3.5 s
Vertical Bearing capacity (kN)	12,500	12,500	30,000	30,000
Lateral horizontal bearing capacity (kN)	/	1,000	/	2,000
Permissible corner (rad)	0.02	0.02	0.02	0.02
Longitudinal temperature displacement (mm)	±200	±200	±200	±200
Lateral temperature displacement (mm)	±50	/	±50	/
Longitudinal seismic displacement (mm)	±300	±300	±300	±300
Longitudinal seismic displacement (mm)	±300	±300	±300	±300

3.3 Longitudinal and Transverse Dampers

Two sets of longitudinal viscous dampers are used at the main tower, while one set of transverse dampers is installed at each of the four transition piers. The technical parameters of both the longitudinal and transverse dampers are shown in Table 2.

Table 2 Technical parameter table of dampers

Position of damper	Maximum damping force (kN)	Maximum displacement (mm)	Damping coefficient C (kN·s/m)	Damping index α
Longitudinal	3,000	400	3,000	0.5
transverse	3,000	200	3,000	0.5

Longitudinal dampers are designed to accommodate the slow displacement of the main beam caused by temperature fluctuations, average wind speeds, and live loads without exerting any constraints on the structure. In the event of an earthquake, these dampers utilize a travel limit device to control longitudinal displacement within ± 400 mm [4].

3.4 Lateral Wind-Resistant Support

To limit lateral displacement of the main beam during strong winds, lateral wind-resistant supports are installed at the bridge tower [5]. These supports adopt PTFE rubber technology, fixed on the wall of the main tower, with a support specification of 30 MN. In the event of an earthquake, these lateral supports can also provide a degree of buffering effect.

4 Bridge Tower Design

4.1 Steel Tower Segmentation

The pylon is a single-column structure with a total height of 146.5 meters (measured from the top of the tower crown to the top of the tower base). The lower tower column stands at 20.0 meters, followed by a steel–concrete transition section of 9.1 m. The middle and upper tower columns measure 54.7 m and 41.2 m, respectively. The height of the tower crown is 21.5 meters. Considering structural durability, stress characteristics, and construction period, the lower tower column is made of concrete, while the middle and upper tower columns are constructed of steel [6]. Given its complex shape, the tower crown also adopts a pure steel structure, as shown in Figure 5. The pylon, excluding the tower crown section, consists of a main structural component and a flanged decorative element.

The elevation at the top of the pylon cap is 59.0 m, with a characteristic elliptical cross-section. The transverse bridge dimension is 12 m, and the longitudinal bridge

dimension is 18 m. From 59.0 meters to 155.0 meters, the characteristic cross-section is a varying elliptical shape, with transverse bridge dimensions ranging from 12 meters to 6 meters and longitudinal bridge dimensions ranging from 18 meters to 12 meters. Above 155.0 meters to 186.5 meters, the characteristic cross-section changes to a circular shape, with diameters ranging from 6 meters to 8.5 meters [7].

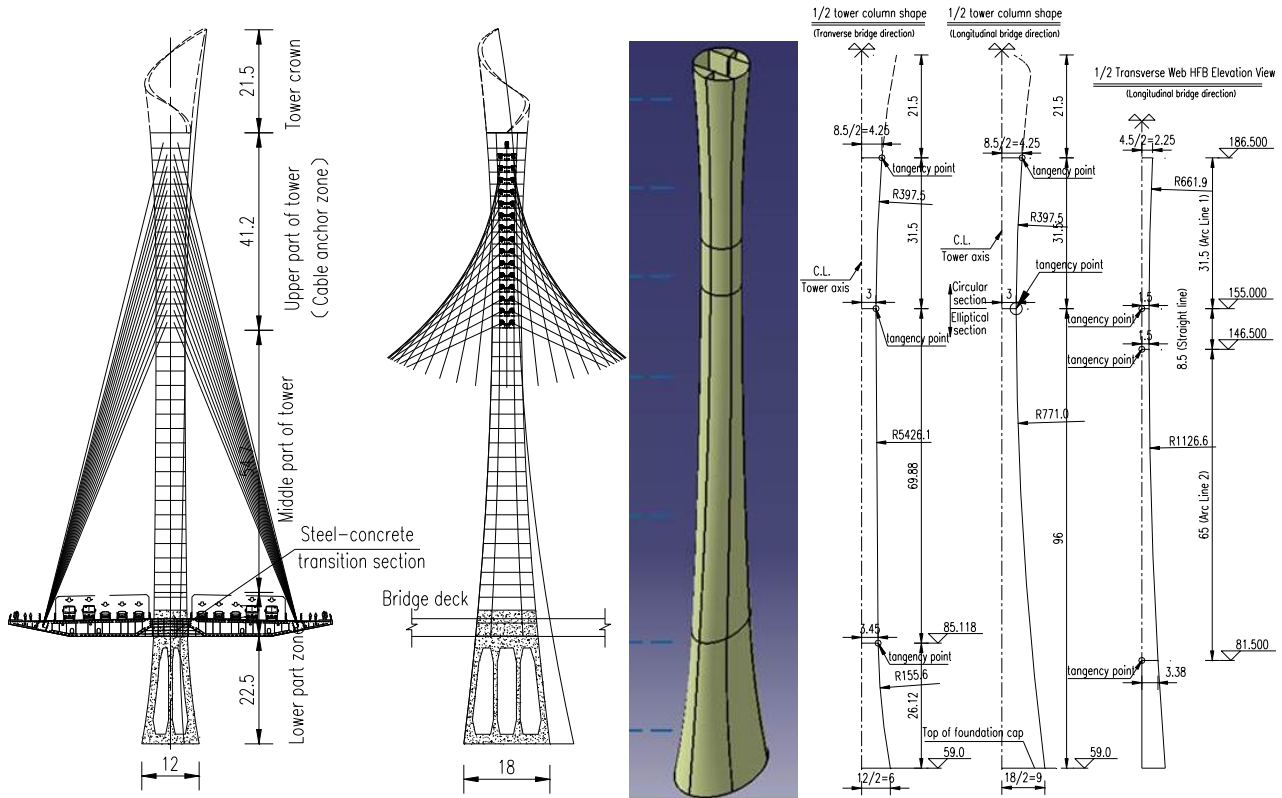

Figure 5 Parameters of bridge tower segmentation and outline (Unit: m)

4.2 Section Design of Steel Tower Section

The steel middle and upper tower columns consist of an outer wall plate, vertical web plates, and horizontal web plates. This form provides a clear load transfer path and facilitates the arrangement of steel anchor beams, as shown in Figure 6.

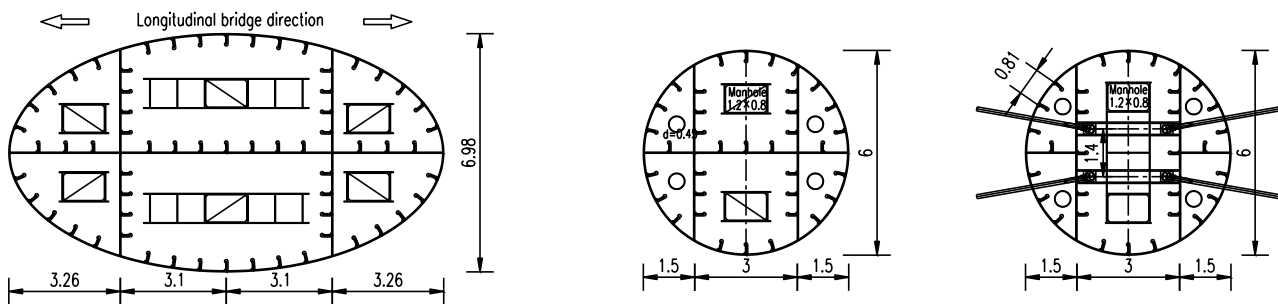

Figure 6 Schematic diagram of the steel tower section (Unit: m)

Within the middle tower column section, the thickness of the outer wall plate transitions from 24 mm to 30 mm while the thickness of the vertical and horizontal web plates transitions from 30 mm to 32 mm. In the upper tower column (anchor cable zone), the thickness of the outer wall plate is uniformly 30 mm, and the vertical and horizontal web plates are uniformly 36 mm thick. Stiffeners of 240 mm × 20 mm are used for 24 mm thick wall plates, while the remaining wall plates and all web plates use stiffeners of 280 mm × 28 mm. These stiffeners are evenly distributed along

the inner surface of the tower wall. However, within the cable anchorage zone, the stiffener arrangement is locally adjusted according to the position of the anchorage structure.

In the anchorage zone of the upper tower column, a series of horizontal diaphragms are set, with thickness of 24 mm and spacing of 2.5 m. Additionally, every 500 mm, four circular stiffeners with a thickness of 24 mm are horizontally set on each diaphragm, located within four small boxes behind the steel anchor beams. In the non-anchorage zone of the middle tower column, a horizontal diaphragm with a thickness of 12 mm is set every 3.0 m.

4.3 Steel Anchor Beam Design

In the anchorage zone of the tower column, 16 pairs of cable anchorage structures are arranged (M1 to M15 are steel anchor beams, and M0 is a steel anchor box). The theoretical anchorage point of the steel anchor box M0 is 0.7 meters from the horizontal diaphragm below it [8]. The web plates of the steel anchor box are welded to both the outer tower wall and the diaphragm below. The distance between the web plates of the steel anchor box is 420 mm, and stiffeners are set perpendicular to the bearing plate position, forming a “#” (intersecting parallels) shape structure together with the web plates. The anchor pad plates are set as wedge-shaped plates to accommodate the sag effect of the cables.

The theoretical anchorage points of the steel anchor beams M1 to M15 are 1.2 m from the horizontal diaphragm below them. The ends of the steel anchor beams are welded to the two transverse web plates of the tower, as shown in Figure 6. A pair of cables in the longitudinal direction of the bridge forms a cable plane, and the web plates of the steel anchor beams are aligned parallel to the corresponding cable plane. The lower flange plates of the steel anchor beams are horizontally arranged and butt-welded to the diaphragms [9]. A typical schematic of a steel anchor beam structure is shown in Figure 7.

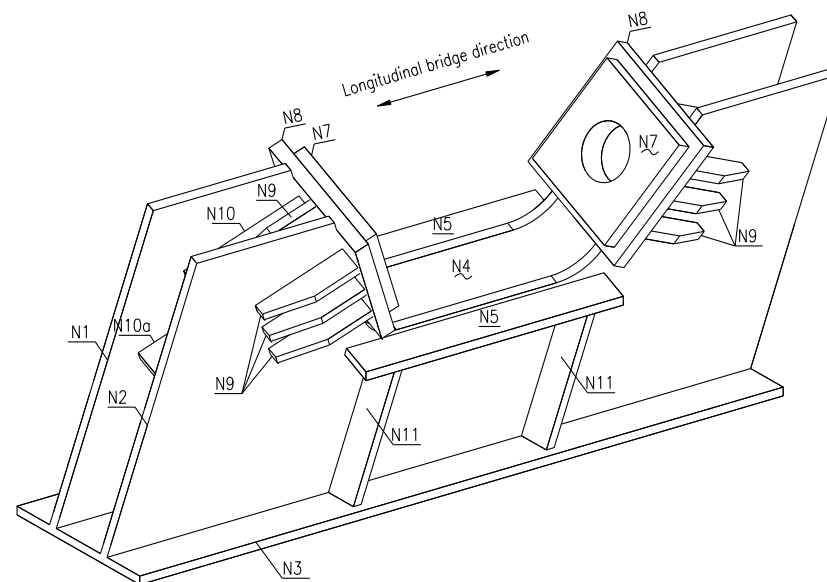

Figure 7 3D Schematic diagram of the steel anchor beam

4.4 Design of Concrete Tower Columns

The lower tower column is a spatially irregular concrete structure with a height of 20 meters and a concrete grade of C50 [10]. The cross-section of the tower column is elliptical, with a wall thickness of 1.2 meters and an internal diaphragm thickness of 0.8 meters, as shown in Figure 8.

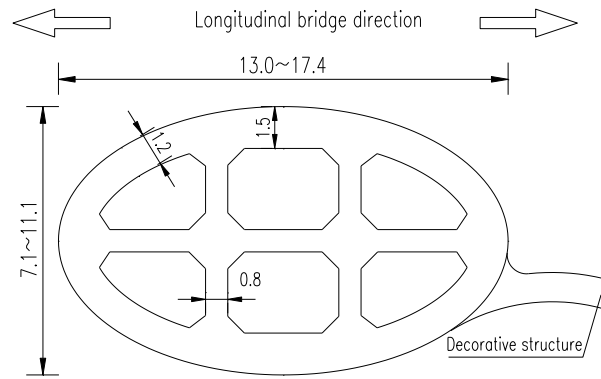

Figure 8 Typical cross-sectional diagram of a concrete lower tower column

4.5 Design of Steel-Concrete Transition Section

A steel-concrete transition section is set between the steel tower column and the concrete tower column, primarily employing a load transfer mechanism based on double end plates under compression. To ensure the integration of the steel structure with the concrete, a combination of PBL connector rebars and shear studs is used [11].

An upper compression end plate, with a thickness of 60 mm, is set 5.4 m above the steel-concrete interface. A lower end plate, 40 mm thick, is set 2.7 m above the steel-concrete interface. These two end plates are connected into a single unit through rectangular steel plates. Some of the rebars from the concrete tower column are anchored in batches onto the two end plates. Within the 2.7 m range below the upper compression end plate to the upper compression end plate, the tower wall stiffeners use T-shaped stiffeners. The height of these stiffeners gradually increase from 360 mm to 800 mm, while the flange plate width and thickness remain at 300 mm and 30 mm, respectively.

To ensure the quality of concrete pouring, both end plates and the inner wall plates are equipped with concrete pouring holes and vent holes. To ensure the connection between the tower wall and the concrete, shear studs with dimensions $\varnothing 22 \times 240$ are uniformly arranged on the inner side of the outer wall plate and on both sides of the inner wall plate below the steel-concrete interface.

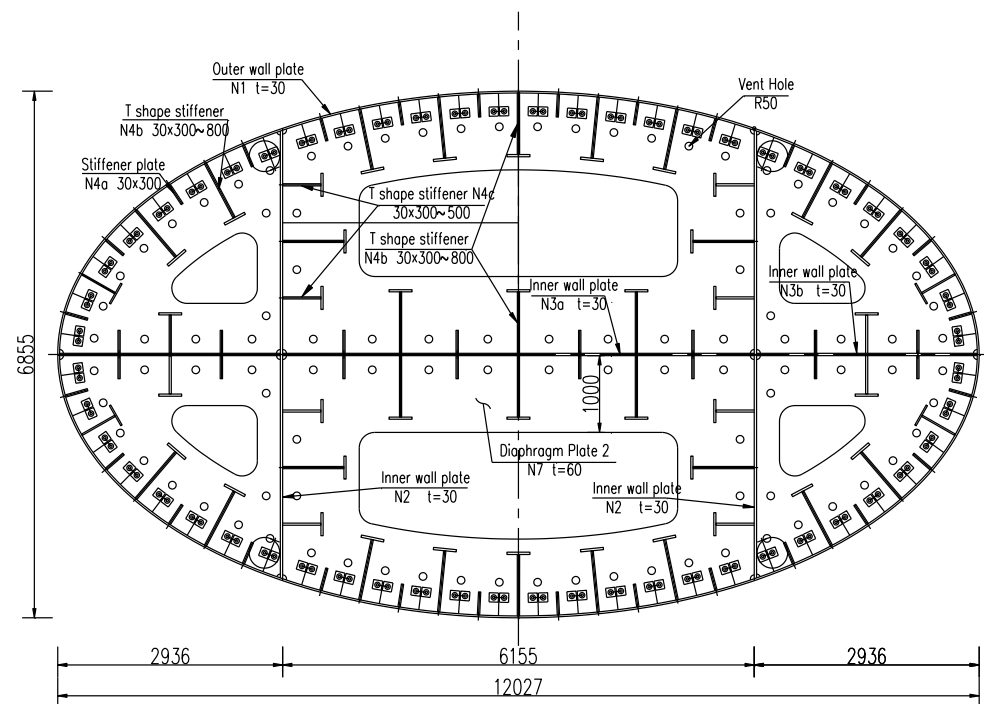

Figure 9 Continue

The rolled edge decoration in the lower tower column section (below the main beam) concrete, seamlessly integrated with the tower column concrete. In contrast, the rolled edge decoration in the upper tower column section (above the main beam) uses a steel structure. The interior of this steel structure comprises an angle steel framework, while the exterior is covered with 10 mm steel plates that are welded and fixed to the main tower wall plate. A 40 mm separation joint is set between the concrete rolled edge decoration and the steel rolled edge decoration, see Figure 11.

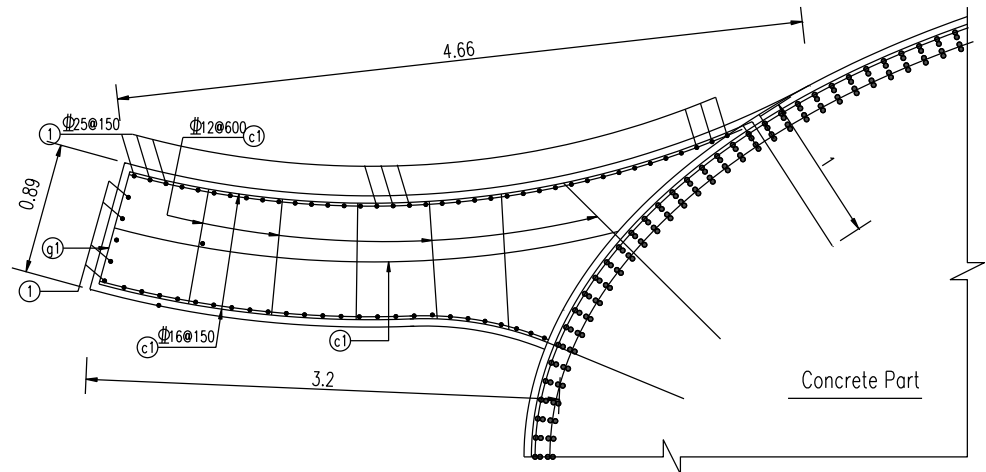

Figure 12 Schematic diagram of the concrete edge rolling structure

5 Main Beam Design

5.1 Main Beam Splitting

The main beam adopts a structure of double amplitude steel box girders and crossbeams, with a centerline height of 3.7 m (measured between the outer edges of the top and bottom plates of the standard segment). The standard section has a full width of 67.0 m, which is locally widened to 73.0 m, a single width of 29.5 m, and a width of 8.0 m in the crossbeam area [12]. The cross-sectional view of a single main beam is shown in Figure 12.

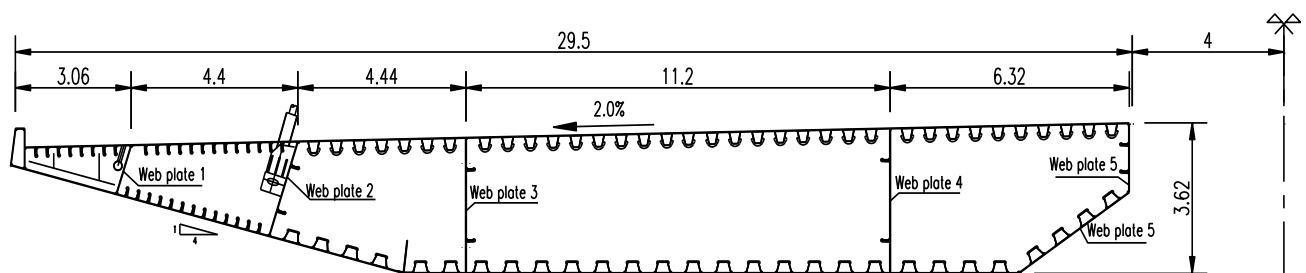

Figure 13 Single-section diagram of the main beam

The standard spacing between crossbeams is the same as the spacing between cables, both being 9.0 m, with a crossbeam width of 3.2 m. Transition piers, auxiliary piers, and both sides of the main tower are reinforced with crossbeams, with the width of these crossbeams adjusted to accommodate structural and stress requirements.

5.2 Longitudinal Segmentation of Main Beam

Considering factors such as construction and installation, the main beam is divided into 10 types and 43 beam segments. The standard segment length of the main

beam is 9.0 m, and the weight of a single segment is approximately 145 tons (excluding the crossbeam). The heaviest main beam segment is located near the auxiliary pier, with a single segment weight of about 245 tons (excluding the crossbeam).

5.3 Main Structure of Main Beam

The thickness of the top and bottom plates of the standard section of the steel box girder is 16 mm, the thickness of the top plate in the pedestrian area is 12 mm, and the thickness of the web plate is 16 mm. According to force requirements, the bottom plate of the beam section near the auxiliary pier should be thickened to 24 mm. The top plate, bottom plate, and web plate are longitudinally reinforced with U-shaped stiffeners and plate stiffeners. The standard spacing between horizontal partitions is 3 m, and solid belly partitions are used [13].

The crossbeam adopts a box-shaped cross-section, with a standard top and bottom plate thickness of 20 mm and a web plate thickness of 16 mm. The standard spacing between crossbeams is 9.0 m, and the cross-sectional width is 3.0 m.

5.4 Steel Anchor Box on the Beam

The anchor box and the main beam web are connected through welding, and the cable is fixed on the anchor box, as shown in Figure 13. Tension is transmitted from the anchor box to the nearby main beam web plate [14]. A reinforcing plate is installed on the inner side of the main beam web to distribute the stress at the anchorage to the main beam in a reasonable manner [15].

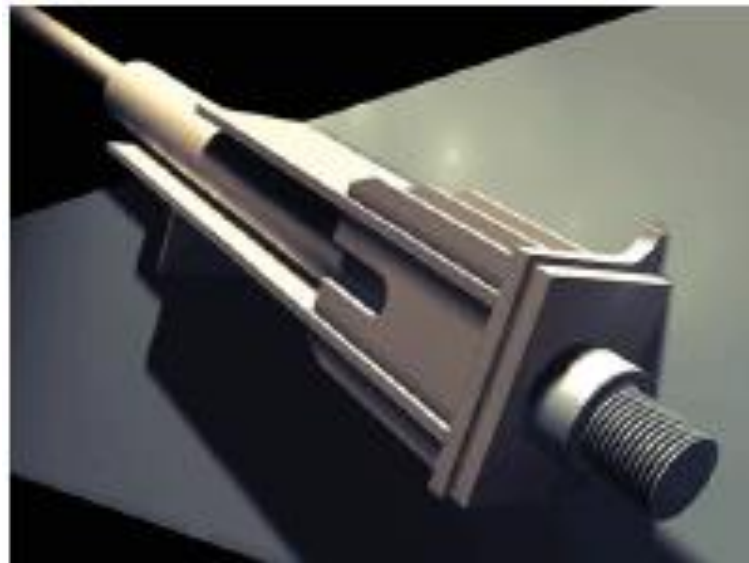

Figure 14 Example diagram of a steel anchor box on a beam

6 Cable Design

During the design process, a comparison was made between steel strand cables and parallel wire cables [16]. Ultimately, standard strength 1860 MPa steel strand cables were selected, with a fatigue stress range of 200 MPa [17]. The bridge has a total of 62 stay cables, with the longest cable measuring approximately 160 m in length and featuring specifications of $\varphi^s15.2-37$, $\varphi^s15.2-43$, and $\varphi^s15.2-55$. The anchor point spacing on the girders is 9 m, while the standard vertical anchor point spacing on the towers is 2.5 m. The cables are arranged in a spatially twisted plane. On the girders, the cables are anchored using steel anchor boxes. On the towers, cables #1 to #15 are anchored using steel anchor beams, and cable #0 uses a steel anchor box. Cables #0 to #5 are tensioned on the tower, whereas cables #6 to #15 are tensioned on the girders. The structural diagram of a steel strand cable see Figure 14.

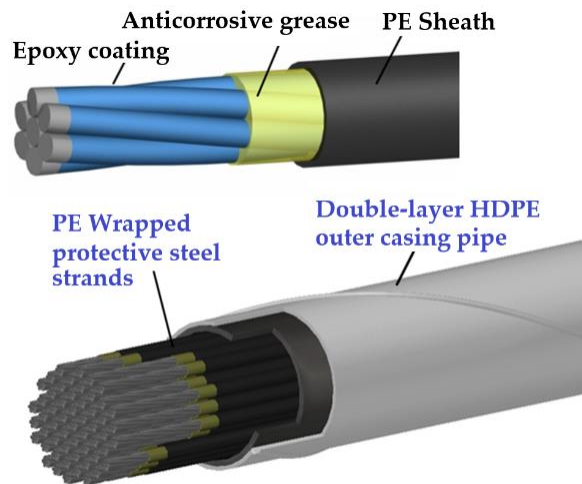

Figure 15 Structural diagram of a steel strand cable

Because some cables have small inclination angles and lengths close to 150 meters, they are prone to vibration under wind loads, which needs to be controlled. Completely suppressing the vibration of the cables is challenging, but measures can be taken to minimize it [18]. The main anti-vibration measures adopted in this project include:

- (1) Helical Filament: The surface of the stay cables is wrapped with helical filaments, with specifications and types selected based on aerodynamic design requirements.
- (2) Internal Dampers: High-damping rubber dampers are used inside the stay cables. These dampers should have sufficient strength and fatigue resistance, be replaceable, and easy to inspect.
- (3) External Dampers: The external dampers use permanent magnetorheological dampers.

7 Substructures

The pylon foundation uses a bored pile cap foundation. Based on flood control evaluation data, the total scouring depth (general scouring + local scouring) is 4.5 m. To meet scouring requirements, the pile cap is embedded to a depth of 5.3 m. The pile cap has a thickness of 4.5 m and is supported by 30 bored cast-in-place piles with a diameter of 2.0 m. A concrete pedestal with a height of 2.5 m is set between the pylon pile cap and the lower tower column.

The auxiliary pier has an approximate height of 21.5 m, with a bottom dimension of 2.3 m in the longitudinal direction of the bridge and 6.0 m in the transverse direction. The pile cap has a thickness of 3.5 m and is supported by six bored cast-in-place piles with a diameter of 2.0 m.

The transition pier has an approximate height of 17.2 m, with a double-column cap beam; it is connected to a small box girder of the approach bridge on the other side. The transition pier is supported by eight bored cast-in-place piles with a diameter of 1.8 meters.

8 Auxiliary Structures

Both motor vehicle lanes and non-motor vehicle lanes are paved with poured asphalt. The sidewalk adopts an angle steel-reinforced rib structure, with 6 mm steel panels, 30 mm mortar, and 30 mm granite tiles laid on top. The elevation of the sidewalk is more than 20 cm higher than the non-motorized vehicle lane pavement. Reserved drainage holes inside the steel pedestrian walkway board are used to drain possible accumulated water. The paving plan for the cable area includes a waterproof bonding layer and 70 mm asphalt sand AC5 (Asphalt Concrete). To protect the cables,

the guardrail of the motor vehicle lane uses HA grade steel guardrail. The sidewalk railings, non-motorized vehicle railings, and cable area railings are all made of steel railings. The cross-section of the standard steel box girder is shown in Figure 2.

A total of 18 dehumidification systems are installed throughout the bridge, including 16 sets on the steel box girders and 2 sets on the steel towers. The steel beam dehumidifier is located within the widest compartment of the two main beams. The bridge tower is equipped with 2 sets of dehumidification systems, positioned above the pressure plate on the upper side of the steel-concrete joint section of the bridge tower. The main equipment and layout of each system are essentially the same, including an integrated air supply and dehumidification machine, as well as corresponding air duct systems and control systems.

Six sets of maintenance vehicles are installed at the bottom of the steel box girder; of these, each side span is equipped with two sets of maintenance vehicles (one set per span), while the two main spans are equipped with two sets of maintenance vehicles (one set per span). The main span maintenance vehicle is extendable and can be extended and retracted in both horizontal and inclined sections. Flat section expansion is used to wrap around the bridge tower, while inclined section expansion is used for inspecting the steel beams of the widened section of the observation platform. There are two maintenance carts inside the steel box girder, powered by lithium batteries and equipped with supporting components such as tracks. In addition, multiple watertight doors are installed within the steel box girder, crossbeam, and steel tower. Climbing ladders are installed inside the steel tower, and climbing ladders and railings are provided at the top of the tower crown for bridge maintenance purposes.

Conflict of Interest: All authors disclosed no relevant relationships.

Date Availability Statement: The data that support the findings of this study are available from the corresponding author, Chen, upon reasonable request.

References

1. Zhao, J. Design of the Main Bridge of Taiyuan Shile Bridge. *Bridge Construction* **2021**, *51*, 116-122.
2. Liu, X.; Xie, B.; Sun, D.; Zhang, P.; Dai, S.; Feng, K.; Yang, J.; LI, J.; Liu, Z.; Zhang, H.; et al. *Seismic Response Characteristics and Energy Dissipation Technology of Single-Tower Cable-Stayed Bridge*; 08/25 2021.
3. Li, Y. Seismic Analysis and Structural System Design of Hengmen West Extra Large Bridge. *Engineering and Technological Research* **2021**, *6*, 215-216, doi:10.19537/j.cnki.2096-2789.2021.16.101.
4. Wang, Z.; Chai, X.; Ma, C. Research of Dampers Used to Mitigate Vibrations for Bridge Structures and Their Application. *Bridge Construction* **2019**, *49*, 7-12.
5. Ruan, H.; Xu, G.; Zhang, Y.; Hu, H.; Kong, L. Transverse Restraint System Design for Main Bridge Structure of Qingshan Changjiang River Highway Bridge in Wuhan. *Bridge Construction* **2020**, *50*, 75-81.
6. Zuo, Z.; Zheng, K.; Chen, J. Overall Stability Analysis of Single-Column Steel Tower of Highway Long-Span Cable-Stayed Bridge. *Sichuan Architecture* **2022**, *42*, 145-148,152, doi:10.3969/j.issn.1007-8983.2022.05.048.
7. Yang, Z. Design of Oval Steel Tower Double-Cable Plane Single-Tower Cable-Stayed Bridge. *Urban Road and Bridge & Flood Control* **2022**, *64*-66,85, doi:10.16799/j.cnki.csdqyfh.2022.09.015.
8. Zhao, W.; Zhou, S. Anchor Structure for Long-Span Cable-Stayed Bridge. *World Bridge* **2019**, *47*, 48-52, doi:10.3969/j.issn.1671-7767.2019.04.010.
9. Zhang, D.; Xu, W.; Huang, X.; Du, P. Optimization Design of Steel Anchor Beams Used as Cable-Pylon Anchorage Structure for Chibi Changjiang River Highway Bridge. *World Bridge* **2019**, *47*, 12-16, doi:10.3969/j.issn.1671-7767.2019.05.003.

10. Zhu, S.; Liu, J. Research on Anti-Cracking Measures for Main Tower of Cable-Stayed Bridge. *Science and Technology Innovation* **2021**, 88-91, doi:10.3969/j.issn.1673-1328.2021.28.032.
11. Yang, Y.; Li, K.; Deng, L.; Guo, J.; Gao, L. Experimental and Numerical Study on Steel Concrete Composite Section of Single Tower Cable Stayed Bridge. *Journal of China & Foreign Highway* **2022**, 42, 62-71, doi:10.14048/j.issn.1671-2579.2022.06.011.
12. Ren, H. Overall Design and Innovation of Single-Tower Cable-Stayed Bridge with Large Cantilever and Wide Beam. *Urban Roads Bridges & Flood Control* **2019**, 43-45,49, doi:10.16799/j.cnki.csdqyfh.2019.10.013.
13. Zhou, W.; Lai, Y.; Li, J. Study on Detail Design of Steel Box Girder of a Single Pylon Cable-stayed Bridge. In Proceedings of the The academic exchange meeting of industrial architecture in 2021, Beijing China, 2021; p. 4.
14. Liu, F.; Liu, X. Study on the Transfer Mechanism of Steel Anchor Box in Anchorage Zone of Cable-beam of Long-span Cable-stayed Bridge. *Transportation Science & Technology* **2021**, 81-83,94, doi:10.3963/j.issn.1671-7570.2021.05.017.
15. Wu, Q. Fatigue Investigation of Steel Anchor Box in Cable-stayed Bridge Based on Field Measurement. Master, Hunan University, Changsha, 2020.
16. Yang, J.; Yu, Q.; Shi, K.; Lu, X. Comparative Analysis of Parallel Steel Strand and Parallel Steel Wire Stay Cable. *Engineering and Construction* **2019**, 33, 38-40, doi:10.3969/j.issn.1673-5781.2019.01.013.
17. Zhu, W.; Liu, F.; Zhu, S.; Huang, F. Experimental Study of Fatigue Performance Optimization for Steel Strand Cables. *World Bridge* **2020**, 48, 46-50, doi:10.3969/j.issn.1671-7767.2020.05.010.
18. Xie, J. Research on Vibration and Control of Cable of Cable-Stayed Bridge under Wind Load. Master, Guizhou University, Guiyang, 2022.

AUTHOR BIOGRAPHIES

	<p>Zineng Chen Senior Engineer. Working at Tongji Architectural Design (Group) Co., Ltd.</p> <p>Research direction: Bridge engineering design research.</p> <p>Email: 375859229@qq.com</p>		<p>Xing Wu Professor Engineer. Working at CCCC First Highway Consultants Co., Ltd.</p> <p>Research Direction: Bridge engineering design research.</p> <p>Email: 420650452@qq.com</p>
---	---	--	---